

## 構造比較圖 COMPARISON

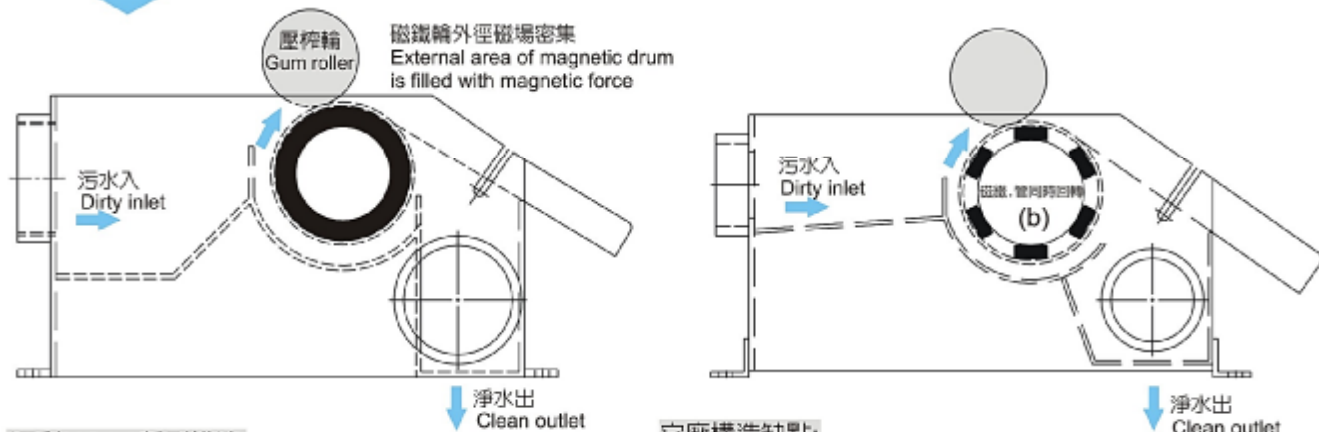

源利MCJ-A新型構造  
特點: 1.接液部磁場密集。

Structure of MCJ-A new type (UNIMAG)  
Feature: 1.The external area of drum closes to the coolant with fully magnetic filed

它廠構造缺點:

特點: (a).未充份利用磁鐵背面磁力,以致磁力太弱。  
(b).磁鐵排列太疏,效果不夠好。

Structure of others:

Feature: (a).Other suppliers did not utilize both sides of magnets, which result in weak magnetic force.  
(b).Magnet arrangement is too loose that causes poor performance.

## 磁場強度 Magnetic field gauss

源利磁鐵過濾機



MCJ-60A  
磁場峰值1600高斯以上,為同業同級品最高值  
Peak value of magnetic zone is higher than 1600 gauss, the highest among similar products.

它廠磁鐵過濾機



磁場峰值800高斯  
Other suppliers owns only 800 gauss.



ISO 9001  
FM 518819

經銷商:  
Distributor



源利電磁工業股份有限公司

UNI MAGNETIC INDUSTRIAL CO., LTD.

彰化縣鹿港鎮彰濱工業區工業西六路23號

No 23, Gongye West 6th Rd, Lukang Town,  
Chang hua Hsien 50544, Taiwan R. O. C

TEL: 886 - 4 - 7810900

FAX : 886 - 4 - 7810901

http : //www.unimag.com.tw

E-mail : unicoltd@ms26.hinet.net

110601-2000



源利電磁

切、研削冷卻液過濾裝置

CUTTING & GRINDING COOLANT FILTRATION SYSTEM

# 鴨子

## 磁鐵過濾機

### DUCK MAGNETIC SEPARATOR

本體為世界首發以"壓鑄"成型  
音似鴨子,因此而命名。



MCJ-60A

專利申請中  
PATENT PENDING

標準色:藍灰色  
Color : RAL 7031

## 適用機械

### APPLICABLE TO MACHINES

- |           |                                |
|-----------|--------------------------------|
| 1. 平面磨床   | 1. Surface Grinder             |
| 2. 無心磨床   | 2. Centerless Grinder          |
| 3. 內、外徑磨床 | 3. Internal / External Grinder |
| 4. 搪磨床    | 4. Honing Machine              |
| 5. 螺紋磨床   | 5. Thread Grinding Machine     |
| 6. 齒輪磨床   | 6. Gear Grinding Machine       |
| 7. 拋光機    | 7. Polisher                    |



## MCJ 40A~160A 外型尺寸圖 DIMENSION

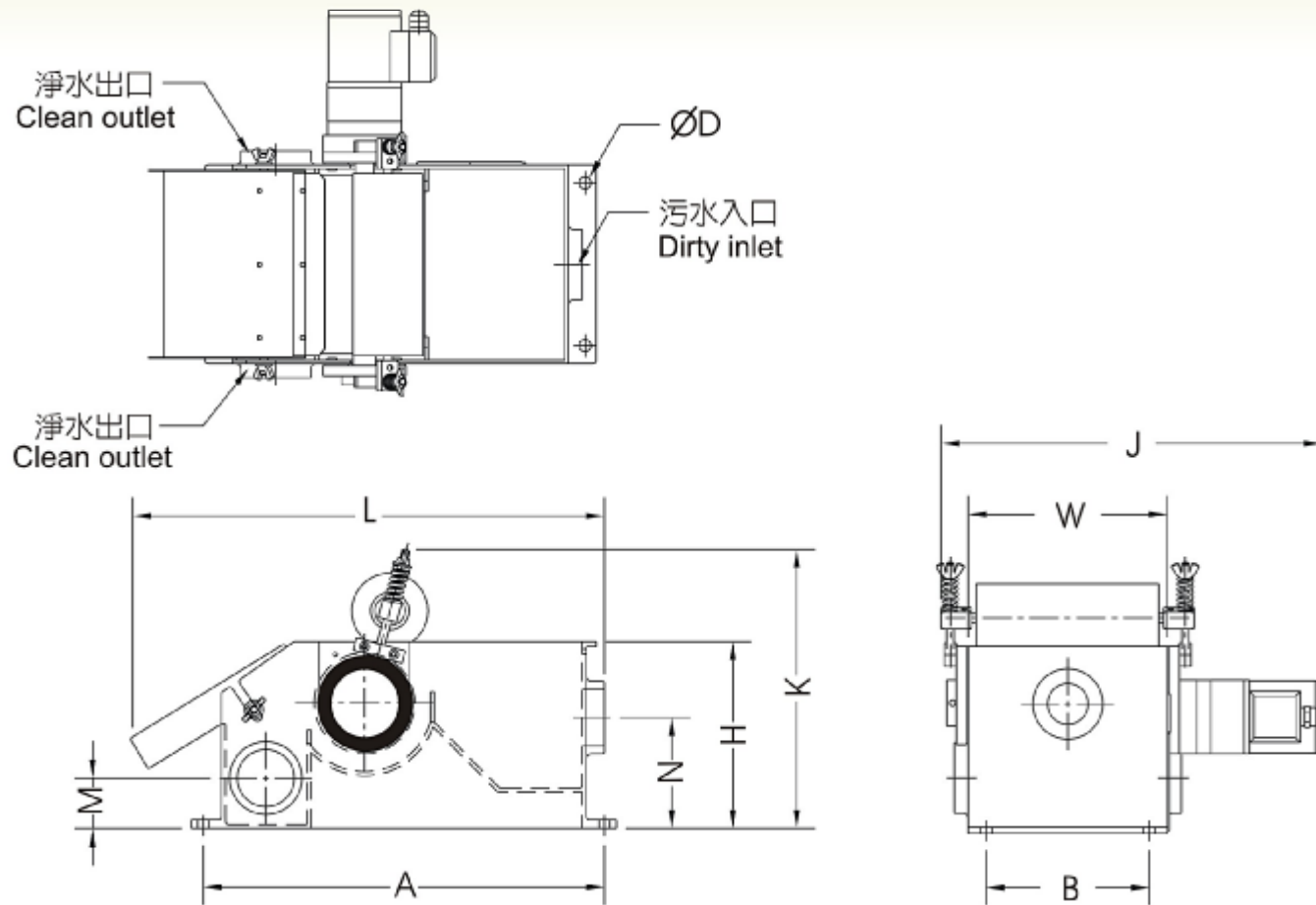

## MCJ 240A 外型尺寸圖 DIMENSION

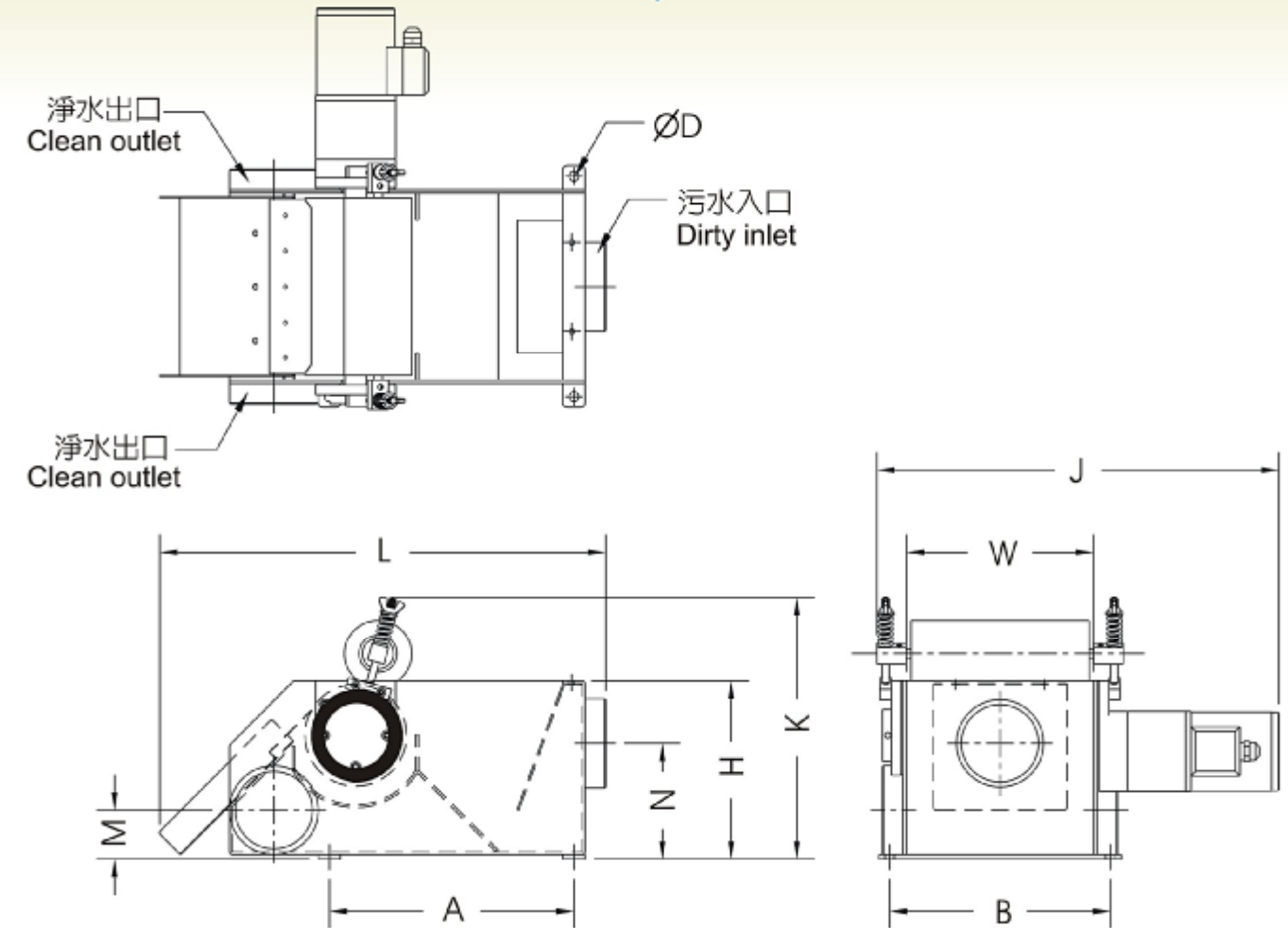

### 特點

1. 使用最高等級氧化鐵永久磁鐵，加上最佳磁路設計，磁力為同業同級品最高值。
2. 磁鐵輪外徑磁場密集，捕捉鐵屑效果佳。
3. 本體以鋁合金壓鑄而成，美觀不漏水，不感應磁性。(註3)
4. 上刮板如磨損，間隙可調整至刮得乾淨。
5. 能將冷卻液中可吸磁雜質吸住，壓乾後自動排出，完全無濾材消耗。
6. 如欲吸除如超硬合金，淬火鋼之脫碳層等弱磁性之雜質或油性研磨液，除鐵輪宜改用強力磁鐵MCJ-※※HK。

### FEATURES:

1. Use superior ferrite permanent magnets and by best magnetic circuit design, the attractive forces are the best among similar products.
2. External area of magnetic drum is filled with magnetic force, perform best in filtration process.
3. Frame is die-cast by aluminum-alloy. Super appearance and leak-proof. Un-attractive to magnetic force. (Note 3)
4. You can adjust the upper scraper while it is wearing.
5. The magnetic drum can attract the impurities from the coolant. After squeezing, it can be discharged automatically and without any consumption.
6. If you want to filter the carbide, carbon remover of hardened steel and oil coolant, we suggest you to purchase **super magnetic separator MCJ-※※HK**.

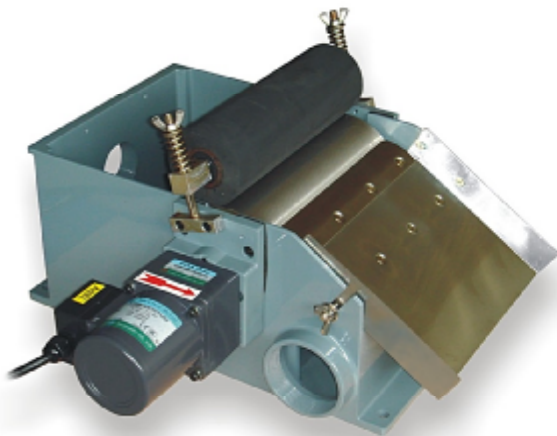

## 鴨子磁鐵過濾機規格尺寸表 DUCK MAGNETIC SEPARATOR SPECIFICATIONS

型號 MODEL	處理能力 FLOW RATE L/MIN	L	W	H	M	N	A	B	D	J	K	入口 INLET O	出口 OUTLET P	馬達 MOTOR	註2 NOTE 2
MCJ-40A	40 Note1	464	150	165	50	110	398	120	ø11	353	280	PT 2"	PT 2"	200/220V 3ø 25W	
MCJ-60A	60		206	185				176		409					
MCJ-80A	80		242					212		445					
MCJ-120A	120	485	270	220	60	140		230		473	315	PT 3"	PT 3"	200/220V 3ø 40W	
MCJ-160A	160		354					314		557					
MCJ-240A	240		503	450				200		125					

- 註: 1. 如用於油性研磨液處理能力應以1/2-1/4計算。(視研磨黏度而定)。 Note: 1. Disposal capacity for oil coolant shall be 1/2-1/4. (Depending on viscosity)
2. 為降低排出屑之含油率可增大齒輪減速比為1/900(特別附件)。 2. In order to reduce the grease rate of exhausting sludge, the ratio of speed-reducing on the gear shall be increase to 1/900. (Extra option)
3. MCJ-240A 除外。 3. Except MCJ-240A.